

# Fabrication Industrielle et Application Mécanique



ROBINETS A FLOTTEUR



BOITES  
A BOUE



JOINTS DE  
DEMONTAGE



LIMITEURS  
DE DEBIT



VENTOUSES  
DOUBLE EFFET



VENTOUSES  
TRIPLE EFFET



VENTOUSES  
EAUX CHARGÉES



## ADAPTATIONS FILETEES POUR POMPES IMMERGEES TYPE PAF



### MARQUE FIAM

Siège Social & Usine FIAM

Adresse : Z.I. EL BASSATINE - BOUM'HEL - 2034 EZZAHRA (TUNISIE)

Tél.: (216) 71 454 040 - 71 454 046 - 71 452 275 Fax: (216) 71 454 075

E-mail : [commercial@fiam.tn](mailto:commercial@fiam.tn)

Site web : [www.fiam.tn](http://www.fiam.tn)



CLAPETS  
ANTI-RETOUR



CLAPETS  
DE PIED



VANNES  
ELASTOMERE



STABILISATEURS  
S1,5xD & S3XD



MANOMETRES  
A GLYCERINE



COMPTEURS  
D'EAU

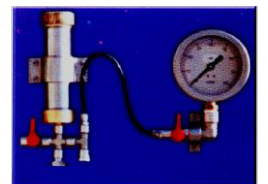

HYDROMETRES

# ADAPTATIONS FILETEES POUR POMPES IMMERGEES

## SERIE PAF

- \* DN 32 à DN 125.
- \* Pression de service 16 bars.
- \* Filetage mâle gaz.
- \* Limites d'utilisation : eaux claires.
- \* Température d'eau max. 70°C.

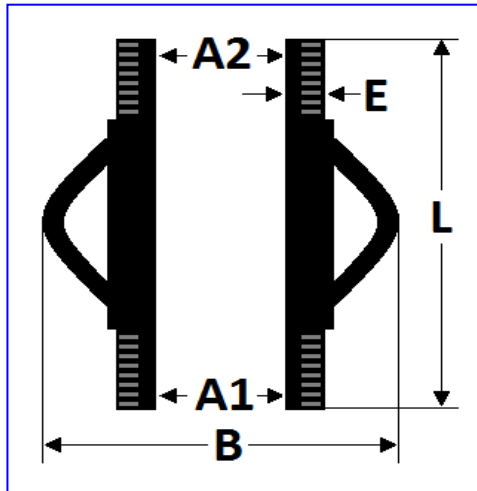

### CONCEPTION ET VARIANTES :

- \* PAF - FF : adaptations filetéés entre les pompes immergées et les tuyaux en PEHD,
- \* tube épais avec filetage mâle de deux côtés avec anneaux pour la corde de maintien,
- \* PAF-/G : adaptations en acier galvanisé,
- \* PAF-/P : adaptations en acier peint.

### OPTIONS :

- \* adaptations avec filetage femelle de deux côtés,
- \* adaptations avec filetage mixte.

## CARACTERISTIQUES

DN			TUYAU PEHD							
			A 1							
			32	40	50	63	75	90	110	125
			1"1/4	1"1/2	2"	2"	2"1/2	3"	4"	5"
POMPE IMMERGEE	32	B	70							
		E	6							
	1"1/4	L	200							
		kg	1							
	40	B	80							
		E	6							
	1"1/2	L	200							
		kg	1,5							
50	B	90								
	E	6								
2"	L	200								
	kg	2								
65	B	120								
	E	8								
2"1/2	L	200								
	kg	3								
80	B							130		
	E							8		
3"	L							250		
	kg							4		
100	B							150		
	E							10		
4"	L							250		
	kg							6		
125	B							175		
	E							12		
5"	L							250		
	kg							8		

### SUR DEMANDE :

- \* adaptations autres dimensions,
- \* revêtements spéciaux.



\* Remarque : La Société FIAM se réserve le droit de modifier sans préavis le matériel représenté ci-dessus.